

PAC•TEC

407 N. County Road Y
Milton, Wisconsin 53563
Phone: 608.207.3260
Fax: 608.207.3267
www.pactecllc.com
email: info@pactecllc.com

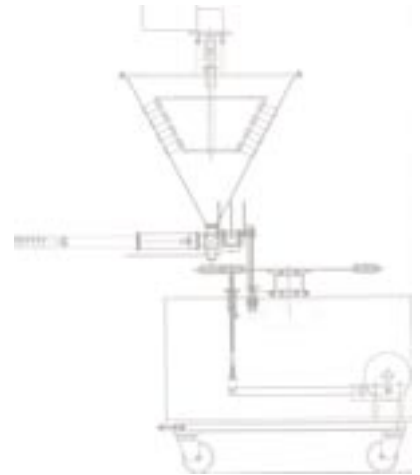

Model PTR-8 Cup Dispensing, Filling and Sealing Machine

The model RPR-8 is an eight station rotary cup filling and sealing machine that offers the best in medium volume output with high reliability.

This machine will denest the containers from a stack using positive drive separating screws and index them through each station. Various types of filling systems are offered including volumetric piston filler, auger fill, weigh scale or an open area for hand filling. The sealing station can use either roll stock film with a die cut or pre-cut foil. The film station has servo film feed for accurate and repeatable film advance or positioning for pre-printed film. The overcap station can be either spinning rails type or pick and place.

This machine is offered with either a mechanical drive heavy duty cam indexer and camshaft or servo controlled with touch screen PLC. Functions such as No Cup- No Fill/ Seal or Overcap are standard.

Typical output rates of up to 40 cups per minute depending on product fill time can be expected. Cup sizes of 1 inch to 6 inch diameter and 1/2 ounce to 80 ounce volume can be accommodated. This machine is also offered in a two lane configuration for greater output quantities.

The machine meets or exceeds USDA or 3A requirements. All components are designed to withstand direct wash down.

Pac Tec, LLC can provide a reliable and profitable solution for your packaging requirements. Please allow us the opportunity to quote on your next project.

